



Modular Cooking Range Line
thermaline 90 - Electric Chip Scuttle,
1/1 GN, 1 Side with Backsplash

ITEM # _____

MODEL # _____

NAME # _____

SIS # _____

AIA # _____



589143 (MCYAABDOBO) Electric Chip Scuttle, one-side operated with backsplash, 1/1 GN

Short Form Specification

Item No. _____

Unit constructed according to DIN 18860_2 with 20 mm drop nose top. Internal frame for heavy duty sturdiness in stainless steel. 2 mm top in 1.4301 (AISI 304). Flat surface construction, easily cleanable. THERMODUL connection system enables seamless worktop when units are connected and avoids soil penetrating. Appliance typically used to keep servings warm until ready to be served or in combination with a fryer to allow fried portions to drip excess oil. Infrared heating elements on the back of the unit to increase holding time. Well able to contain 1/1 GN container with a maximum height of 150 mm. Easy to use control panel. Supplied with a perforated GN 1/1 false bottom. Metal knobs with embedded hygienic silicon "soft" grip enable easier handling and cleaning. IPX5 water resistant certification. Configuration: One-side operated top with backsplash. The base is supplied by the factory

Main Features

- All major components may be easily accessed from the front.
- THERMODUL connection system creates a seamless work top when units are connected to each other thus avoiding soil penetrating vital components and facilitating the removal of units in case of replacement or service.
- Metal knobs with embedded hygienic "soft-touch" grip for easier handling and cleaning. The special design of the controls prevents infiltration of liquids or soil into vital components.
- Easy-to-use control panel.
- The appliance is used to keep servings warm until ready to be served to customer.
- Unit supplied with a perforated GN 1/1 false bottom specially shaped for easier food collection.
- Unit to have infrared heating elements positioned on the back of the unit to increase holding time.
- Well able to contain 1/1 GN container with a maximum height of 150 mm.
- Typically used in combination with a fryer to allow fried portions to drip excess oil into the well basin.
- Large visible digital display manufactured in tempered glass to resist heat and chemicals, showing temperatures or power settings. The display also shows on/off status of the appliance and on/off status of the heating elements.

Construction

- 2 mm top in 1.4301 (AISI 304).
- Flat surface construction with minimal hidden areas to easily clean all surfaces
- Internal frame for heavy duty sturdiness in 1.4301 (AISI 304).
- IPX5 water resistance certification.
- Unit constructed according to DIN 18860_2 with 20 mm drop nose top.
- Unit constructed according to DIN 18860_2 with 20 mm drop nose top and 70 mm recessed plinth.

APPROVAL: _____



Front

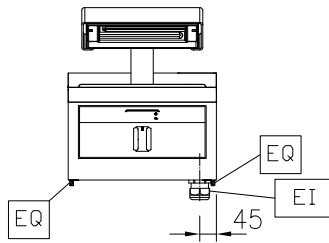

Side

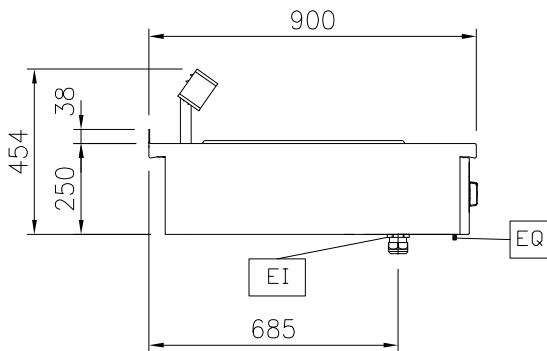

EI = Electrical inlet (power)

Top

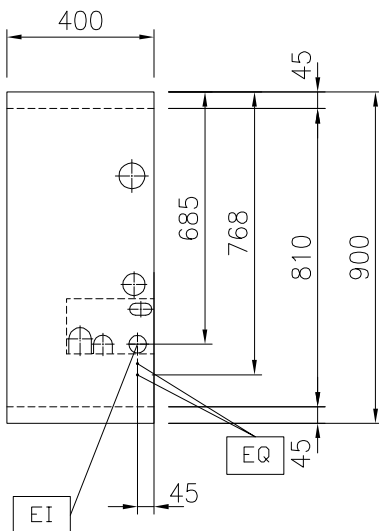

Electric

Supply voltage:	230 V/1N ph/50/60 Hz
Total Watts:	1 kW

Key Information:

Usable well dimensions (width):	306 mm
Usable well dimensions (height):	156 mm
Usable well dimensions (depth):	510 mm
External dimensions, Width:	400 mm
External dimensions, Depth:	900 mm
External dimensions, Height:	250 mm
Net weight:	16 kg

Sustainability

Current consumption:	4.3 Amps
----------------------	----------

Optional Accessories

- Connecting rail kit for appliances with backsplash, 900mm PNC 912499
- Portioning shelf, 400mm width PNC 912522
- Portioning shelf, 400mm width PNC 912552
- Folding shelf, 300x900mm PNC 912581
- Folding shelf, 400x900mm PNC 912582
- Fixed side shelf, 200x900mm PNC 912589
- Fixed side shelf, 300x900mm PNC 912590
- Fixed side shelf, 400x900mm PNC 912591
- Connecting rail kit for appliances with backsplash: modular 90 (on the left) to ProThermetic tilting (on the right), ProThermetic stationary (on the left) to ProThermetic tilting (on the right) PNC 912981
- Connecting rail kit for appliances with backsplash: modular 90 (on the right) to ProThermetic tilting (on the left), ProThermetic stationary (on the right) to ProThermetic tilting (on the left) PNC 912982
- Back panel, 400x700mm, for units with backsplash PNC 913009
- Back panel, 400x800mm, for units with backsplash PNC 913022
- Endrail kit, flush-fitting, with backsplash, left PNC 913117
- Endrail kit, flush-fitting, with backsplash, right PNC 913118
- Endrail kit (12.5mm) for thermaline 90 units with backsplash, left PNC 913208
- Endrail kit (12.5mm) for thermaline 90 units with backsplash, right PNC 913209
- U-clamping rail for back-to-back installations with backsplash (to be ordered as S-code) PNC 913226
- Insert profile d=900 PNC 913232
- Stainless steel side panel (12,5mm), 900x400mm, left side, wall mounted PNC 913636
- Stainless steel side panel (12,5mm), 900x400mm, right side, wall mounted PNC 913637
- Stainless steel side panel, 900x400mm, flush-fitting, left side, wall mounted PNC 913638
- Stainless steel side panel, 900x400mm, flush-fitting, right side, wall mounted PNC 913639
- Wall mounting kit top - TL85/90 - Factory Fitted PNC 913648
- Filter W=400mm PNC 913663